

# Ring Joint Facings - ASME/ANSI B16.5 & B16.47

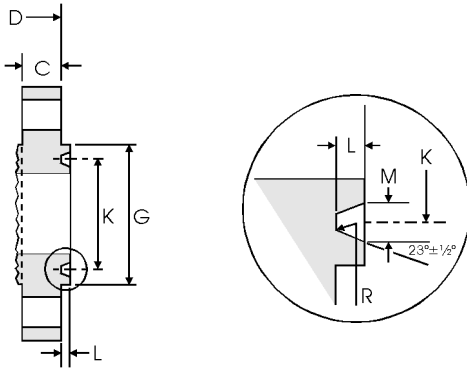

**Note**

- Values for minimum flange thickness, C, and overall length, D, are detailed in the flange tables.
- For ring joint tolerances see page 8-9.

**Ring joint facing dimensions - ASME/ANSI B16.5 and B16.47 Series A (MSS SP-44) and Series B (API 605)**

Class (lb)						Groove/Ring Number	Raised Face	Groove				
150	300	400	600	900	1500		2500	G	K	L	M	R
Nominal Pipe Size (NPS)							Face Diameter min	Pitch Diameter	Depth <sup>1</sup>	Width	Radius at Bottom	
							in mm	in mm	in mm	in mm	in mm	
ASME/ANSI B16.5 covers NPS 1/2 to 24:												
	1/2		1/2			R11	2.000 50.80	1.344 34.14	0.219 5.56	0.281 7.14	0.03 0.76	
				1/2		R12	2.380 60.45	1.562 39.67	0.250 6.35	0.344 8.74	0.03 0.76	
	3/4		3/4			R13	2.500 63.50	1.688 42.88	0.250 6.35	0.344 8.74	0.03 0.76	
				1/2		R13	2.560 65.02	1.688 42.88	0.250 6.35	0.344 8.74	0.03 0.76	
				3/4		R14	2.620 66.55	1.750 44.45	0.250 6.35	0.344 8.74	0.03 0.76	
1						R15	2.500 63.50	1.875 47.63	0.250 6.35	0.344 8.74	0.03 0.76	
	1		1			R16	2.750 69.85	2.000 50.80	0.250 6.35	0.344 8.74	0.03 0.76	
				1		R16	2.810 71.37	2.000 50.80	0.250 6.35	0.344 8.74	0.03 0.76	
					3/4	R16	2.880 73.15	2.000 50.80	0.250 6.35	0.344 8.74	0.03 0.76	
	1 1/4		1 1/4			R17	2.880 73.15	2.250 57.15	0.250 6.35	0.344 8.74	0.03 0.76	
						R18	3.120 79.25	2.375 60.33	0.250 6.35	0.344 8.74	0.03 0.76	
				1 1/4		R18	3.190 81.03	2.375 60.33	0.250 6.35	0.344 8.74	0.03 0.76	
					1	R18	3.250 82.55	2.375 60.33	0.250 6.35	0.344 8.74	0.03 0.76	
	1 1/2		1 1/2			R19	3.250 82.55	2.562 65.07	0.250 6.35	0.344 8.74	0.03 0.76	
				1 1/2		R20	3.560 90.42	2.688 68.28	0.250 6.35	0.344 8.74	0.03 0.76	
				1 1/2		R20	3.620 91.95	2.688 68.28	0.250 6.35	0.344 8.74	0.03 0.76	
					1 1/4	R21	4.000 101.60	2.844 72.24	0.312 7.92	0.469 11.91	0.03 0.76	
						R22	4.000 101.60	3.250 82.55	0.250 6.35	0.344 8.74	0.03 0.76	
						R23	4.250 107.95	3.250 82.55	0.312 7.92	0.469 11.91	0.03 0.76	
					1 1/2	R23	4.500 114.30	3.250 82.55	0.312 7.92	0.469 11.91	0.03 0.76	
				2		R24	4.880 123.95	3.750 95.25	0.312 7.92	0.469 11.91	0.03 0.76	
	2 1/2		2 1/2			R25	4.750 120.65	4.000 101.60	0.250 6.35	0.344 8.74	0.03 0.76	
						R26	5.000 127.00	4.000 101.60	0.312 7.92	0.469 11.91	0.03 0.76	
					2	R26	5.250 133.35	4.000 101.60	0.312 7.92	0.469 11.91	0.03 0.76	

Use Class 600 for sizes ≤ 3 1/2

Use Class 1500 for sizes ≤ 2 1/2

# Ring Joint Facings - ASME/ANSI B16.5 & B16.47

Ring joint facing dimensions - ASME/ANSI B16.5 and B16.47 Series A (MSS SP-44) and Series B (API 605) (Continued)

Class (lb)							Groove/Ring Number	Groove				
150	300	400	600	900	1500	2500		<b>G</b>	<b>K</b>	<b>L</b>	<b>M</b>	<b>R</b>
Nominal Pipe Size (NPS)								Face Diameter min	Pitch Diameter	Depth <sup>1</sup>	Width	Radius at Bottom
								in mm	in mm	in mm	in mm	in mm
					2 1/2		R27	5.380 136.65	4.250 107.95	0.31 27.92	0.469 11.91	0.03 0.76
						2 1/2	R28	5.880 149.35	4.375 111.3	0.375 9.53	0.531 13.49	0.06 1.52
3							R29	5.250 133.35	4.500 114.30	0.250 6.35	0.344 8.74	0.03 0.76
	2						R30	-	4.625 117.48	0.312 7.92	0.469 11.91	0.03 0.76
	3 <sup>2</sup>						R31	5.750 146.05	4.875 123.83	0.312 7.92	0.469 11.91	0.03 0.76
				3			R31	6.120 155.45	4.875 123.83	0.312 7.92	0.469 11.91	0.03 0.76
					3		R32	6.620 168.15	5.000 127.00	0.375 9.53	0.531 13.49	0.06 1.52
3 1/2							R33	6.060 153.92	5.188 131.78	0.250 6.35	0.344 8.74	0.03 0.76
	3 1/2						R34	6.250 158.75	5.188 131.78	0.312 7.92	0.469 11.91	0.03 0.76
					3		R35	6.620 168.15	5.375 136.53	0.312 7.92	0.469 11.91	0.03 0.76
4							R36	6.750 171.45	5.875 149.23	0.250 6.35	0.344 8.74	0.03 0.76
	4	4	4				R37	6.880 174.75	5.875 149.23	0.312 7.92	0.469 11.91	0.03 0.76
				4			R37	7.120 180.85	5.875 149.23	0.312 7.92	0.469 11.91	0.03 0.76
					4		R38	8.000 203.20	6.188 157.18	0.438 11.13	0.656 16.66	0.06 1.52
					4		R39	7.620 193.55	6.375 161.93	0.312 7.92	0.469 11.91	0.03 0.76
5							R40	7.620 193.55	6.750 171.45	0.250 6.35	0.344 8.74	0.03 0.76
	5	5	5				R41	8.250 209.55	7.125 180.98	0.312 7.92	0.469 11.91	0.03 0.76
				5			R41	8.500 215.90	7.125 180.98	0.312 7.92	0.469 11.91	0.03 0.76
					5		R42	9.500 241.30	7.500 190.50	0.500 12.70	0.781 19.84	0.06 1.52
6							R43	8.620 218.95	7.625 193.68	0.250 6.35	0.344 8.74	0.03 0.76
					5		R44	9.000 228.60	7.625 193.68	0.312 7.92	0.469 11.91	0.03 0.76
	6	6	6				R45	9.500 241.30	8.312 211.12	0.312 7.92	0.469 11.91	0.03 0.76
				6			R45	9.500 241.30	8.312 211.12	0.312 7.92	0.469 11.91	0.03 0.76
					6		R46	9.750 247.65	8.312 211.12	0.375 9.53	0.531 13.49	0.06 1.52
					6		R47	11.000 279.40	9.000 228.60	0.500 12.70	0.781 19.84	0.06 1.52
8							R48	10.750 273.05	9.750 247.65	0.250 6.35	0.344 8.74	0.03 0.76
	8	8	8				R49	11.880 301.75	10.625 269.88	0.312 7.92	0.469 11.91	0.03 0.76
				8			R49	12.120 307.85	10.625 269.88	0.312 7.92	0.469 11.91	0.03 0.76
					8		R50	12.500 317.50	10.625 269.88	0.438 11.13	0.656 16.66	0.06 1.52
					8		R51	13.380 339.85	11.000 279.40	0.562 14.27	0.906 23.01	0.06 1.52
10							R52	13.000 330.20	12.000 304.80	0.250 6.35	0.344 8.74	0.03 0.76
	10	10	10				R53	14.000 355.60	12.750 323.85	0.312 7.92	0.469 11.91	0.03 0.76
				10			R53	14.250 361.95	12.750 323.85	0.312 7.92	0.469 11.91	0.03 0.76
					10		R54	14.620 371.35	12.750 323.85	0.438 11.13	0.656 16.66	0.06 1.52

# Ring Joint Facings - ASME/ANSI B16.5 & B16.47

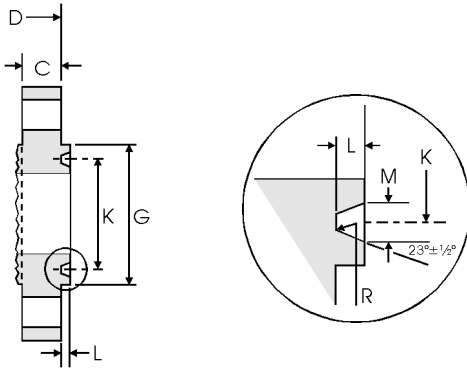

**Note**

- Values for minimum flange thickness, C, and overall length, D, are detailed in the flange tables.
- For ring joint tolerances see page 8-9.

**Ring joint facing dimensions - ASME/ANSI B16.5 and B16.47 Series A (MSS SP-44) and Series B (API 605) (Continued)**

Class (lb)							Groove/Ring Number	Raised Face	Groove			
150	300	400	600	900	1500	2500		G	K	L	M	R
Nominal Pipe Size (NPS)								Face Diameter min	Pitch Diameter	Depth <sup>1</sup>	Width	Radius at Bottom
								in mm	in mm	in mm	in mm	in mm
						10	R55	16.750 425.45	13.500 342.90	0.688 17.48	1.188 30.18	0.09 2.29
12							R56	16.000 406.40	15.000 381.00	0.250 6.35	0.344 8.74	0.03 0.76
	12	12	12				R57	16.250 412.75	15.000 381.00	0.312 7.92	0.469 11.91	0.03 0.76
				12			R57	16.500 419.10	15.000 381.00	0.312 7.92	0.469 11.91	0.03 0.76
					12		R58	17.250 438.15	15.000 381.00	0.562 14.27	0.906 23.01	0.06 1.52
14							R59	16.750 425.45	15.625 396.88	0.250 6.35	0.344 8.74	0.03 0.76
						12	R60	19.500 495.30	16.000 406.40	0.688 17.48	1.312 33.32	0.09 2.29
	14	14	14				R61	18.000 457.20	16.500 419.10	0.312 7.92	0.469 11.91	0.03 0.76
				14			R62	18.380 466.85	16.500 419.10	0.438 11.13	0.656 16.66	0.06 1.52
					14		R63	19.250 488.95	16.500 419.10	0.625 15.88	1.062 26.97	0.09 2.29
16							R64	19.000 482.60	17.875 454.03	0.250 6.35	0.344 8.74	0.03 0.76
	16	16	16				R65	20.000 508.00	18.500 469.90	0.312 7.92	0.469 11.91	0.03 0.76
				16			R66	20.620 523.75	18.500 469.90	0.438 11.13	0.656 16.66	0.06 1.52
					16		R67	21.500 546.10	18.500 469.90	0.688 17.48	1.188 30.18	0.09 2.29
18							R68	21.500 546.10	20.375 517.53	0.250 6.35	0.344 8.74	0.03 0.76
	18	18	18				R69	22.620 574.55	21.000 533.40	0.312 7.92	0.469 11.91	0.03 0.76
				18			R70	23.380 593.85	21.000 533.40	0.500 12.70	0.781 19.84	0.06 1.52
					18		R71	24.120 612.65	21.000 533.40	0.688 17.48	1.188 30.18	0.09 2.29
20							R72	23.500 596.90	22.000 558.80	0.250 6.35	0.344 8.74	0.03 0.76
	20	20	20				R73	25.000 635.00	23.000 584.20	0.375 9.53	0.531 13.49	0.06 1.52
				20			R74	25.500 647.70	23.000 584.20	0.500 12.70	0.781 19.84	0.06 1.52
					20		R75	26.500 673.10	23.000 584.20	0.688 17.48	1.312 33.32	0.09 2.29
24							R76	28.000 711.20	26.500 673.10	0.250 6.35	0.344 8.74	0.03 0.76
	24	24	24				R77	29.500 749.30	27.250 692.15	0.438 11.13	0.656 16.66	0.06 1.52
				24			R78	30.380 771.65	27.250 692.15	0.625 15.88	1.062 26.97	0.09 2.29

# Ring Joint Facings - ASME/ANSI B16.5 & B16.47

## Ring joint facing dimensions - ASME/ANSI B16.5 and B16.47 Series A (MSS SP-44) and Series B (API 605) (Continued)

Class (lb)							Groove/Ring Number	Raised Face		Groove				
150	300	400	600	900	1500	2500		G	K	L	M	R		
Nominal Pipe Size (NPS)								Face Diameter min	Pitch Diameter	Depth <sup>1</sup>	Width	Radius at Bottom		
								in mm	in mm	in mm	in mm	in mm		
					24		R79	31.250 793.75	27.250 692.15	0.812 20.62	1.438 36.53	0.09 2.29		
MSS SP-44 only, covers NPS 22:														
	22	22	22				R81	27.000 685.80	25.000 635.00	0.438 11.13	0.594 15.09	0.06 1.52		
ASME/ANSI B16.47 (MSS SP-44 & API 605) covers NPS 26 to 36. (There are no ring joint facings >NPS 36)														
	26	26	26				R93	31.880 809.75	29.500 749.30	0.500 12.70	0.781 19.84	0.06 1.52		
	28	28	28				R94	33.880 860.55	31.500 800.10	0.500 12.70	0.781 19.84	0.06 1.52		
	30	30	30				R95	36.120 917.45	33.750 857.25	0.500 12.70	0.781 19.84	0.06 1.52		
	32	32	32				R96	38.750 984.25	36.000 914.40	0.562 14.27	0.906 23.01	0.06 1.52		
	34	34	34				R97	40.750 1035.1	38.000 965.20	0.562 14.27	0.906 23.01	0.06 1.52		
	36	36	36				R98	43.000 1092.2	40.250 1022.4	0.562 14.27	0.906 23.01	0.06 1.52		
				26			R100	32.750 831.85	29.500 749.30	0.688 17.48	1.188 30.18	0.09 2.29		
				28			R101	35.000 889.00	31.500 800.10	0.688 17.48	1.312 33.32	0.09 2.29		
				30			R102	37.250 946.15	33.750 857.25	0.688 17.48	1.312 33.32	0.09 2.29		
				32			R103	39.500 1003.3	36.000 914.40	0.688 17.48	1.312 33.32	0.09 2.29		
				34			R104	42.000 1066.8	38.000 965.20	0.812 20.62	1.438 36.53	0.09 2.29		
				36			R105	44.250 1124.0	40.250 1022.4	0.812 20.62	1.438 36.53	0.09 2.29		

### Notes

- Ring joint gasket dimensions conform to ASME B16.20 (not covered in this summary).
  - Use Class 600 lb in sizes NPS 1/2 to NPS 3 1/2 for Class 400 lb.
  - Use Class 1500 lb in sizes NPS 1/2 to NPS 2 1/2 for Class 900 lb.
  - Tolerances are as shown in the table below.
- 1 The height of the raised portion is equal to the depth of groove dimension L, but is not subject to the tolerances for L.
  - 2 Ring joints with lapped flanges in Classes 300 lb and 600 lb use R30 instead of R31.

### Ring joint facing tolerances (ASME/ANSI B16.5 and B16.47)

Dimension	Range	Tolerance	
		in	mm
L (depth)	All	+0.016, -0	+0.406, -0
M (width)	All	±0.008	±0.203
K (pitch diameter)	All	±0.005	±0.127
R (radius at bottom)	R ≤ 0.06 in	+0.03, -0	+0.762, -0
	R > 0.06 in	±0.03	±0.762
D (overall length) for flanges with ring joint	≤ NPS 10	±0.06	±1.52
	≥ NPS 12	±0.12	±3.05