

JIS B2220-1984(KSB 1503-1985)

30Kg/Cm² SLIP-ON WELDING STEEL PIPE FLANGES

A-TYPE NOMINAL SIZE 10-400mm

B-TYPE NOMINAL SIZE 10-50mm

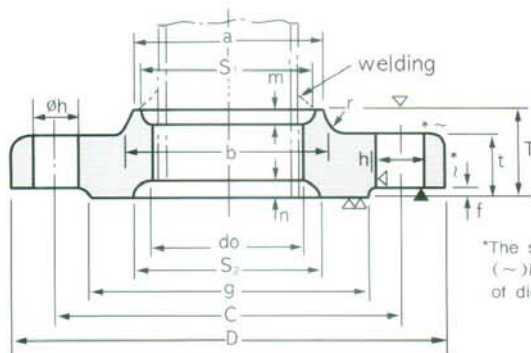

*The surface finish (~) is in the case of die forging.

C-TYPE NOMINAL SIZE 65-400mm

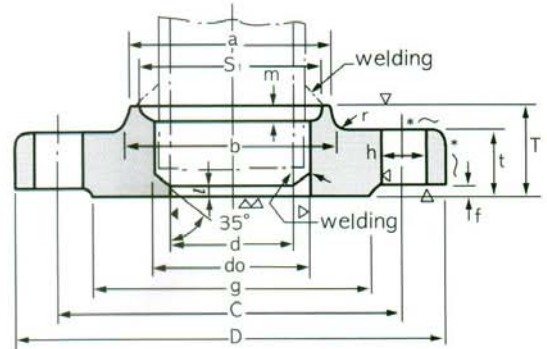

Unit: m

Nominal Diameter of Flange	Outside Diameter of Steel Pipe	Inside Diameter of Flange do	Outside Diameter of Flange D	Sectional Dimensions of Flange								Bolt Hole				Reference					Approx Weight (kg)	
				t	T	Diameter of Hub		Rad-ius r	f	g	d	Bolt Circle Diameter C	Number of Bolt Holes	Hole Diameter h	Nominal Bolt Size	s1	m	s2	n	l	SOH	BL
						a	b															
10	17.3	17.8	110	16	24	30	34	4	1	52	-	75	4	19	M16	-	-	-	-	-	0.99	1.00
15	21.7	22.2	115	18	26	36	40	5	1	55	-	80	4	19	M16	31	4	40	5	-	1.23	1.25
20	27.2	27.7	120	18	28	42	46	5	1	60	-	85	4	19	M16	37	5	44	5	-	1.34	1.38
25	34.0	34.5	130	20	30	50	54	5	1	70	-	95	4	19	M16	44	6	52	5	-	1.76	1.84
32	42.7	43.2	140	22	32	60	64	6	2	80	-	105	4	19	M16	52	6	60	5	-	2.15	2.32
40	48.6	49.1	160	22	34	66	70	6	2	90	-	120	4	23	M20	58	6	66	5	-	2.82	3.00
50	60.5	61.1	165	22	36	82	86	6	2	105	-	130	8	19	M16	70	6.5	78	5	-	2.89	3.14
65	76.3	77.1	200	26	40	102	106	8	2	130	65.9	160	8	23	M20	96	9.5	94	5	6	4.70	5.50
80	89.1	90.0	210	28	44	115	121	8	2	140	78.1	170	8	23	M20	109	9.5	-	-	6	5.36	6.63
(90)	101.6	102.6	230	30	46	128	134	8	2	150	90.2	185	8	25	M22	122	9.5	-	-	6	6.85	8.55
100	114.3	115.4	240	32	48	141	147	8	2	160	102.3	195	8	25	M22	135	9.5	-	-	6	7.89	10.0
125	139.8	141.2	275	36	54	166	172	8	2	195	126.6	230	8	25	M22	160	9.5	-	-	6	11.4	15.3
150	165.2	166.6	325	38	58	196	204	8	2	235	151.0	275	12	27	M24	186	9.5	-	-	6	16.7	22.2
200	216.3	218.0	370	42	64	248	256	8	2	280	199.9	320	12	27	M24	237	9.5	-	-	6	20.6	32.6
250	267.4	269.5	450	48	72	306	314	10	2	345	248.8	390	12	33	M30×3	290	10	-	-	6	36.1	55.2
300	318.5	321.0	515	52	78	360	370	10	3	405	297.9	450	16	33	M30×3	345	12	-	-	6	49.9	77.9
350	355.6	358.1	560	54	84	402	412	12	3	450	333.4	495	16	33	M30×3	383	13	-	-	6	61.2	96.9
400	406.4	409.0	630	60	92	456	468	15	3	510	381.0	560	16	39	M36×3	435	14	-	-	7	85.2	136

- REMARKS: 1. As far as possible, nominal diameter in parenthesis should be avoid from use.
 2. The dimensional tolerance shall confirm to JIS B2203.
 3. The flange gasket surface is based on large raised facing specified in JIS B2202. But, if necessary, facings other than the large raised facing specified in JIS B2201 can be designated by customers.
 4. Size d is an example of pipe thickness for schedule 40 of JIS G3454 and JIS B3456. When other size is necessary, customer can order it at will.
 5. Material
 Carbon Steel: S25C specified in JIS G4051, or SF440A specified in JIS G3201.
 Molybdenum Steel: 1/2 Mo Steel specified in tables 1 and 2 of JIS B2215.
 Chromium-Molybdenum Steel: 1/4 Cr 1/2 Mo Steel specified in tables 1 and 2 of JIS B2215.
 *The surface finish is in the case of forging (Δ: in other cases)