

**Norwegian Standard (NS) Plain Flanges**

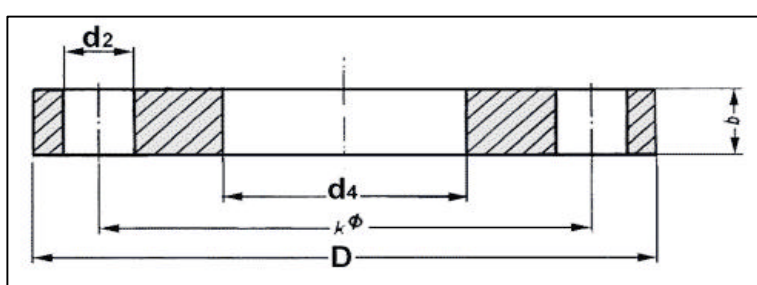

Plain Welding Flange NS2525 PN6								
DN	flange				Bolts			weight
	d4 mm	D mm	b mm	k mm	no.	size	d2 mm	kg/ea
15	21.3	80	12	55	4	M 10	11	0.41
20	26.9	90	14	65	4	M 10	11	0.6
25	33.7	100	14	75	4	M 10	11	0.74
32	42.4	120	16	90	4	M 12	14	1,190
40	48.3	130	16	100	4	M 12	14	1,390
50	60.3	140	16	110	4	M 12	14	1,530
65	76.1	160	16	130	4	M 12	14	1,890
80	88.9	190	18	150	4	M 16	18	2,980
100	114.3	210	18	170	4	M 16	18	3,460
125	139.7	240	20	200	8	M 16	18	4,600
150	168.3	265	20	225	8	M 16	18	5,220
200	219.1	320	22	280	8	M 16	18	7,150
250	273	375	24	350	12	M 16	18	9,610
300	323.9	440	24	395	12	M 20	22	12.6

Plain Welding Flange NS2526 PN10									
DN	flange					Bolts			weight
	d1 mm	D mm	b mm	d4 mm	k mm	no.	size	d2 mm	kg/ea apx.
200	219.1	340	24	221.5	295	8	M 20	22	9,380
250	273	394	26	276	350	12	M 20	22	11,900
300	323.9	445	26	327	400	12	M 20	22	13.7
350	355.6	506	28	359	460	16	M20	22	20.4
400	406.4	565	32	410	515	16	M24	26	27.7
450	457	615	34	461	565	20	M24	26	31.9
500	508	670	34	512	620	20	M24	26	36.3
600	610	780	36	614	725	20	M27	30	47.3
700	711	895	38	716	840	24	M27	30	64.3
800	813	1015	42	818	950	24	M27	30	84.1

Plain Welding Flange NS2527 PN16									
DN	flange					Bolts			weight
	d1 mm	D mm	b mm	d4 mm	k mm	no.	size	d2 mm	kg/ea apx.
15	21.3	95	12	22	65	4	M 12	14	0.574
20	26.9	105	14	27.5	75	4	M 12	14	0.818
25	33.7	115	14	34.5	85	4	M 12	14	1,030
32	42.4	140	16	43	100	4	M 16	18	1,620
40	48.3	150	16	49	110	4	M 16	18	1,850
50	60.3	165	18	61	125	4	M 16	18	2,460
65	76.1	185	18	77	145	4	M 16	18	2,990
80	88.9	200	20	90	160	8	M 16	18	3,610
100	114.3	220	22	115.5	180	8	M 16	18	4,390
125	139.7	250	24	141.5	210	8	M 16	18	5,880
150	168.3	285	24	170.5	240	8	M 20	22	7,120
200	219.1	340	26	221.5	295	12	M 20	22	9,700
250	273	405	32	276	355	12	M 24	26	15,700
300	323.9	460	32	327	410	12	M 24	26	19.1
350	355.6	520	36	359	470	16	M24	26	29
400	406.4	580	38	410	525	16	M27	30	36
450	457	640	38	461	585	20	M27	30	41.9
500	508	715	40	512	650	20	M30	36	56
600	610	840	44	614	770	20	M33	36	82.1

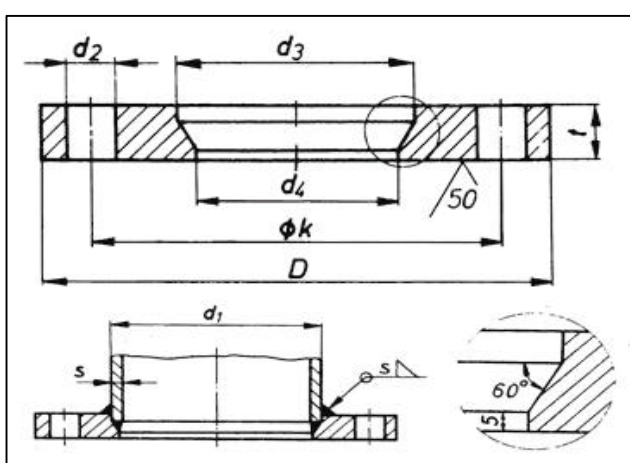

Plain Welding Flange NS2529 PN40									
DN	flange					Bolts			
	d1 mm	D mm	t mm	k mm	mm	No.	Bolt	d2 mm	
40	48.3	150	18	110	45	88	4	M 16	18
50	60.3	165	20	125	48	102	4	M 16	18
65	76.1	185	22	145	52	122	8	M 16	18
80	88.9	200	24	160	58	138	8	M 16	18
100	114	235	24	190	65	162	8	M 20	22
125	140	270	26	220	68	188	8	M 24	26
150	168	300	28	250	75	218	8	M 24	26
200	219	375	30	320	88	285	12	M 27	30
250	273	450	32	385	105	345	12	M 30	33

**Norwegian Standard (NS) Flanges**

NS2537 / NS2538 PIX ONLY

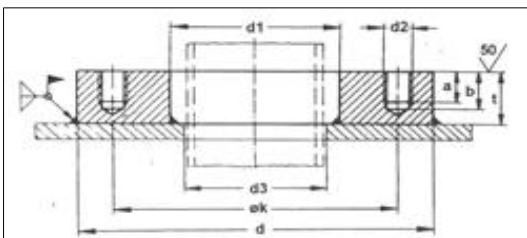

NS2539 / NS2540 / NS2542 PIX ONLY

